

ECLISUM

- ENG** Congratulations with your purchase! Please completely read and follow all the instructions.
- NL** Proficiat met uw aankoop! Gelieve alle instructies te lezen en op te volgen.
- FR** Félicitations avec votre achat. Lisez svp les instructions complètes.
- DE** Herzlichen Glückwunsch zu Ihrem Kauf! Bitte vollständig lesen und befolgen Sie alle Anweisungen.
- ES** Felicidades con su compra! Por favor lea y siga todas las instrucciones.
- IT** Congratulazioni con il Vs. acquisto! Vi preghiamo di leggere bene le istruzioni e di seguirne scrupolosamente le indicazioni.

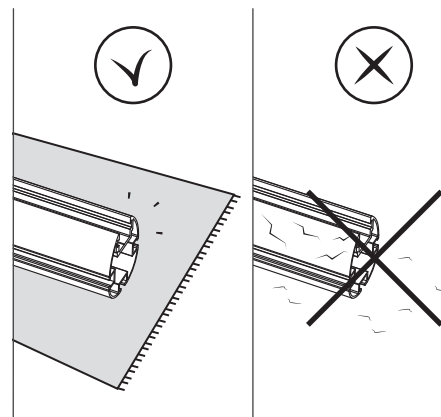

INSTALLATION OPTIONS

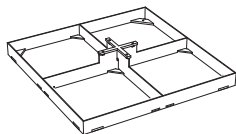

p3

/

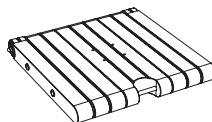

p7

/

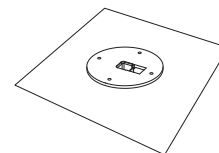

p11

ECLIPSUM



INSTALLATION

p15



USER INSTRUCTIONS

p23



DO'S AND DONT'S

p26



SPARE PARTS

p29

TILE BASE INSTALLATION

UMFIXILMOBG0000

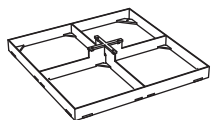
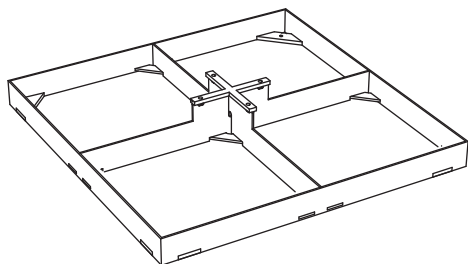

MAFIXILMOBG0000



MABOLI0490

4x



MACOMU020B

4x

OPTIONS

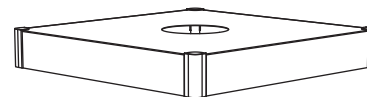

UMFIXTOPMOBA0000

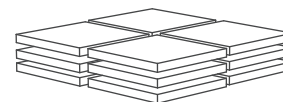

UMFIXTILES120000



UMBASM80FLOOEXT

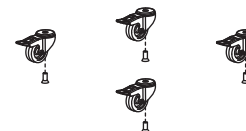

UMBASEWHEELH00

TILE BASE INSTALLATION

1

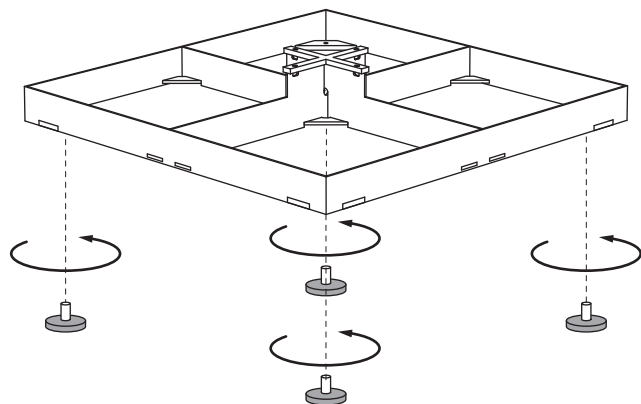
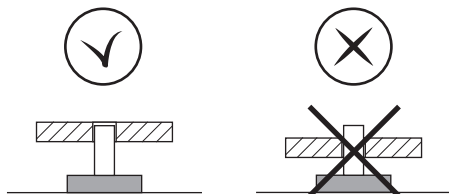
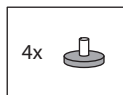

OR OPTION : UMBASM80FL00EXT

1'

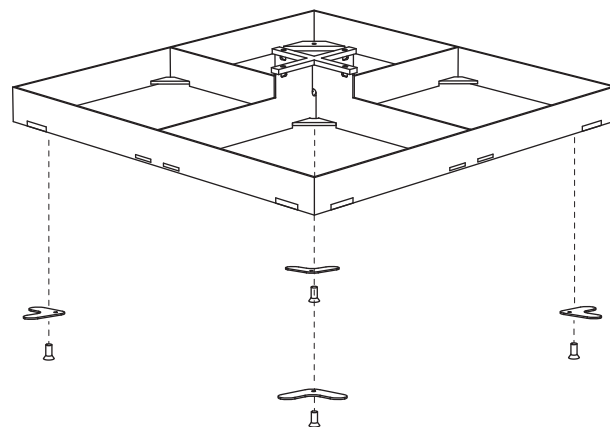
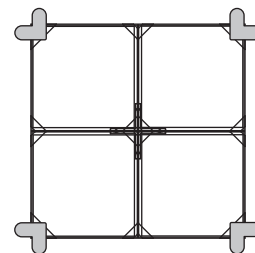
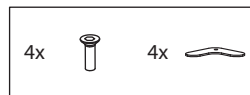

TILE BASE INSTALLATION

OR OPTION : UMBASEWHEELH00

1"

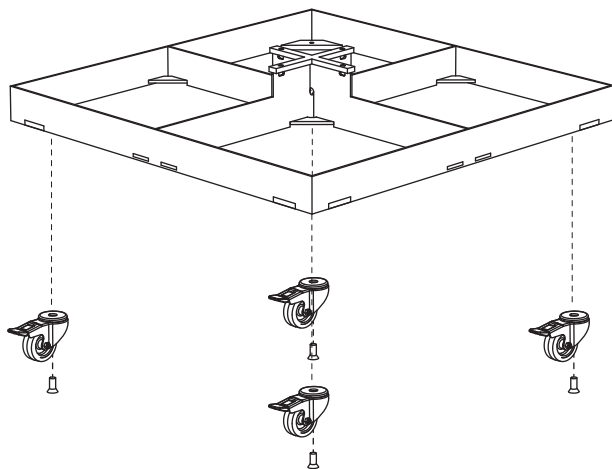
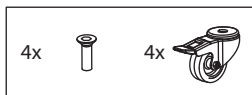

UMFIXTILES120000

2

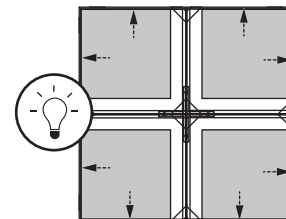
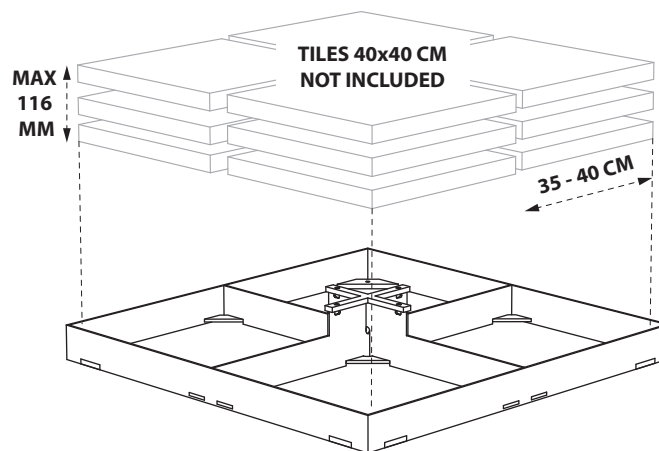

UMBROSA / 5

TILE BASE INSTALLATION

OPTIONAL : UMFIXTOPMOBA0000

3

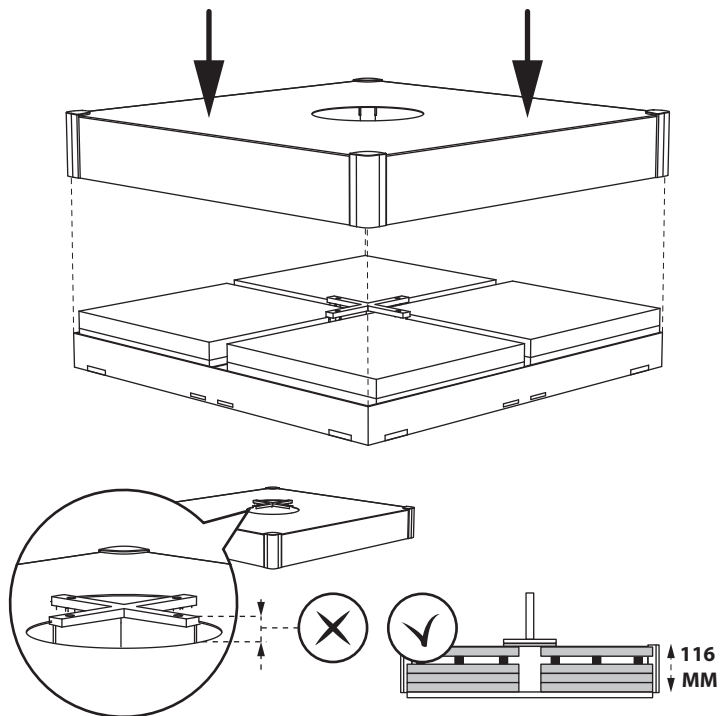

4

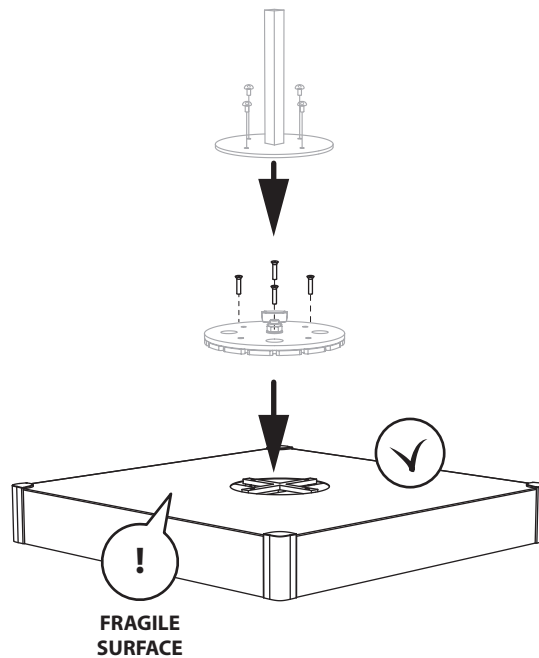

MOBILE CONCRETE BASE INSTALLATION

UMBASM80SET00000

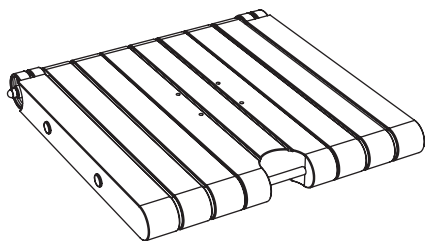

UMBASMHAN

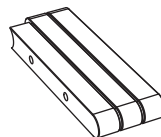

MABASM800L

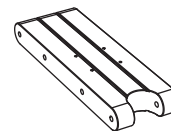

MABASM800M

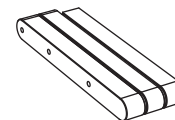

MABASM800R



MABOLI0650
4x



MACOMU002B
4x



HUTUBI0040
2x



HUAXIB0030
1x



MACOMU004C
4x



MACOMU002N
2x



MAWASI0110
2x



MANUTI0160
3x



HUBOLZ0010
+ **MANUTI0170**
2x



HUBOLZ0011
+ **MANUTI0170**
1x



MABOLI0530
6x



MACOMU018B
6x



MACOMU017B
2x



MACOMU005B
4x



19



S5

MOBILE CONCRETE BASE INSTALLATION



1

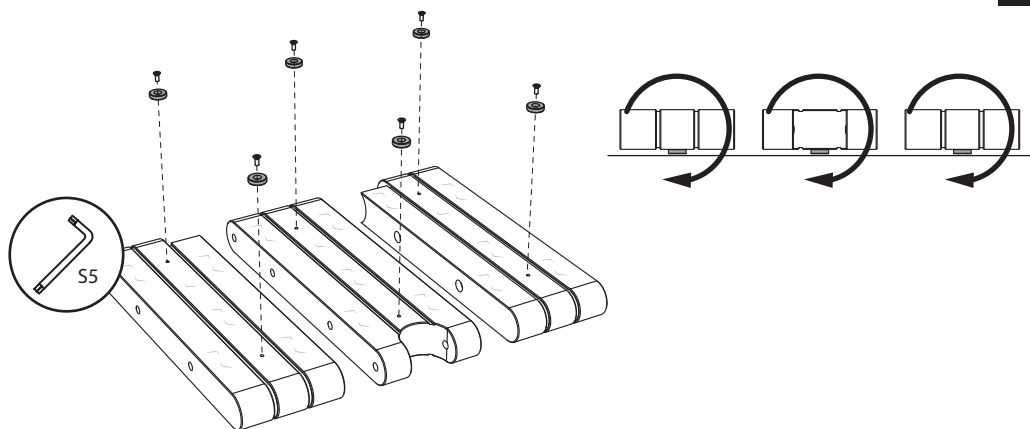
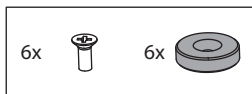

2

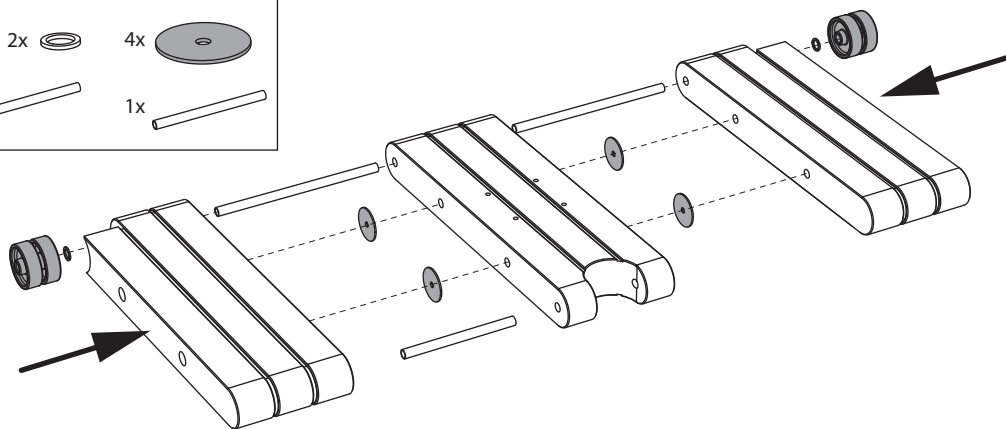
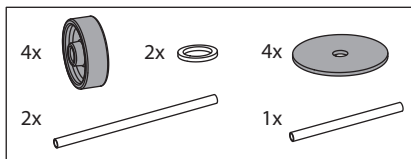

MOBILE CONCRETE BASE INSTALLATION

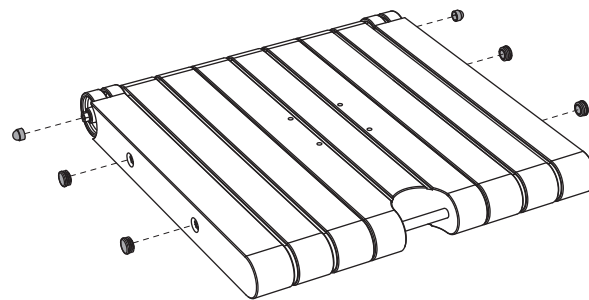
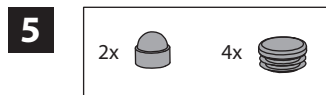
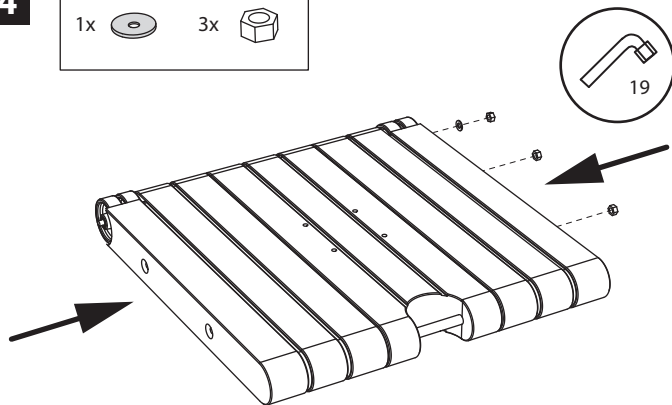
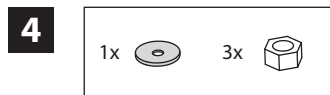
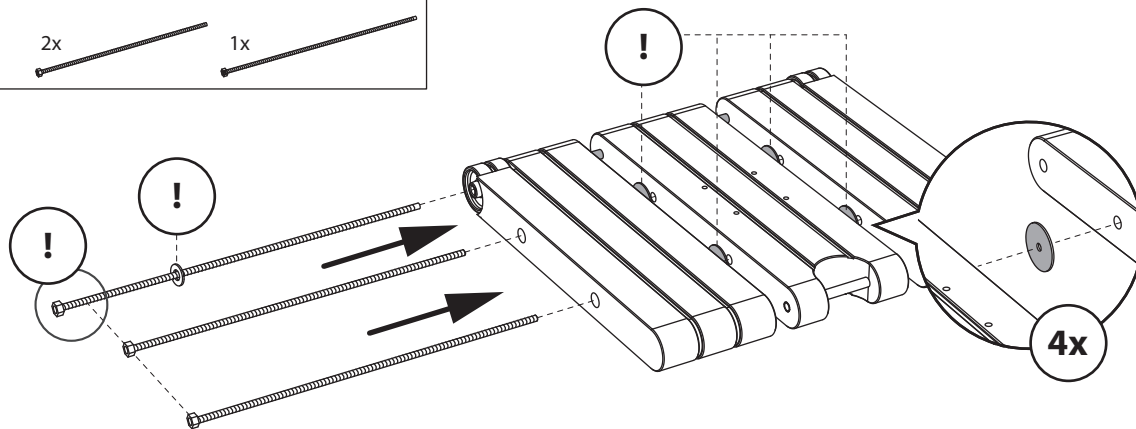
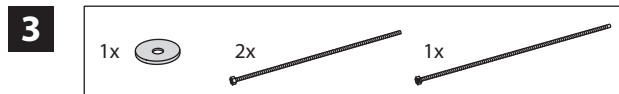

MOBILE CONCRETE BASE INSTALLATION

6

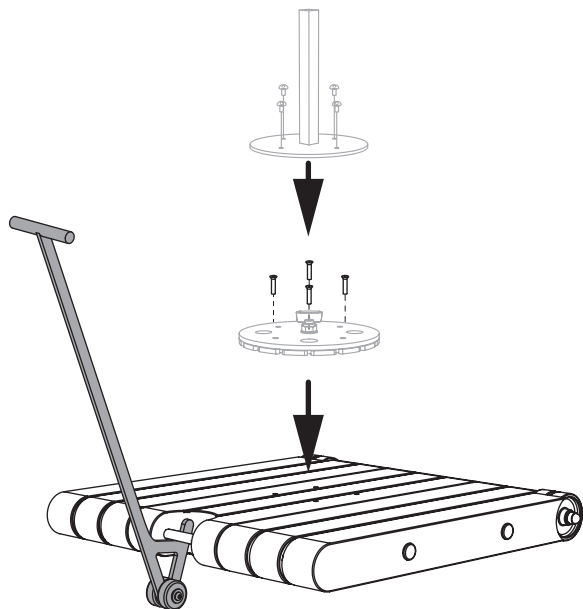

OPTIONAL : UMBASM80FL00EXT



7

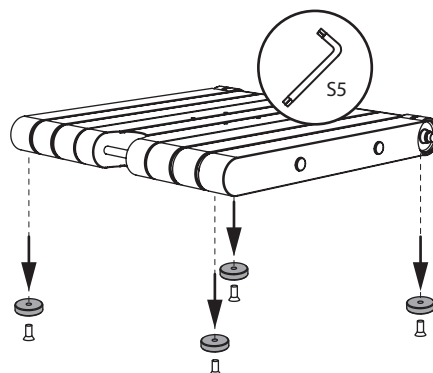

8

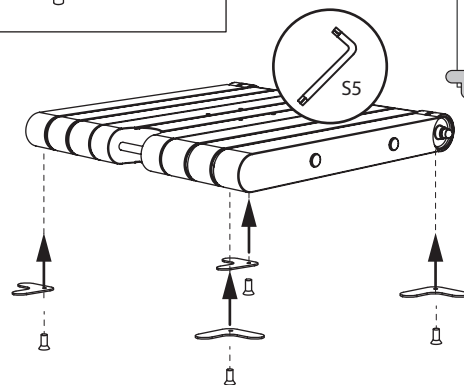
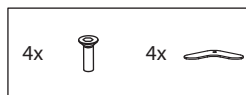

CONCRETE ANCHOR INSTALLATION

UMFIXCROTG000000



1

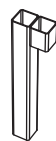
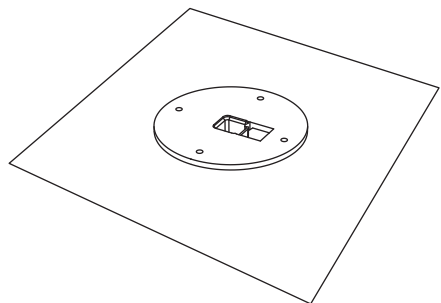

HITUBG0000

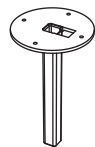

MAFIXCROTG000000

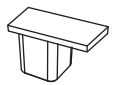

MAPLAI0060

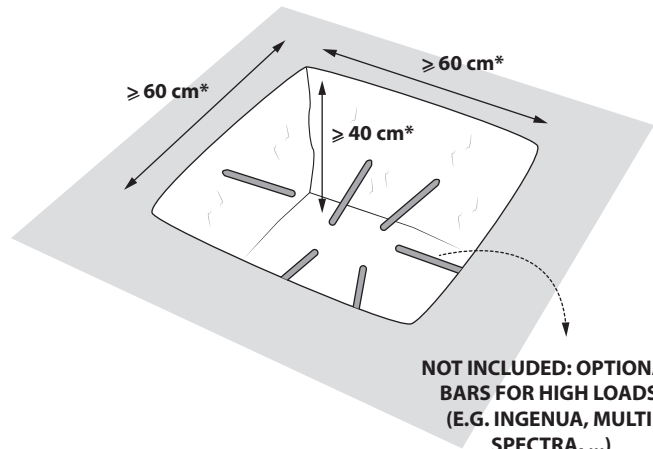

**NOT INCLUDED: OPTIONAL
BARS FOR HIGH LOADS
(E.G. INGENUA, MULTI
SPECTRA, ...)**

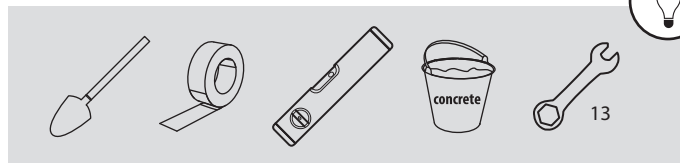

- EN** Dimensions are indicative. Final responsibility always lies with the installer.
- NL** Maten zijn informatief. Eindverantwoordelijkheid ligt bij installateur.
- FR** Les dimensions indiquées sont seulement à titre informatif. La responsabilité finale incombe à l'installateur.
- DE** Die Maße sind nur informativ. Der Installateur trägt die Verantwortung für die Ausführung.
- ES** Los tamaños son solamente informativos. El instalador es responsable del acabado final.
- IT** Dimensioni sono indicative. La responsabilità finale spetta sempre all'installatore.

13

CONCRETE ANCHOR INSTALLATION



2

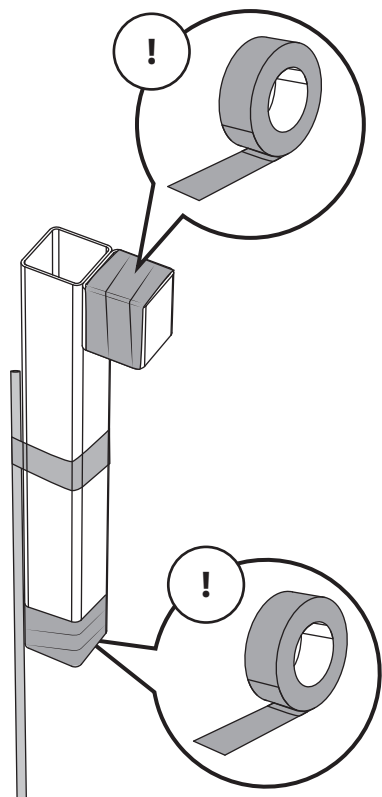

3

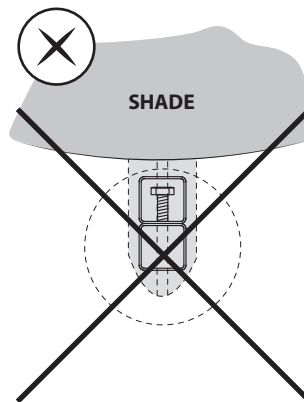
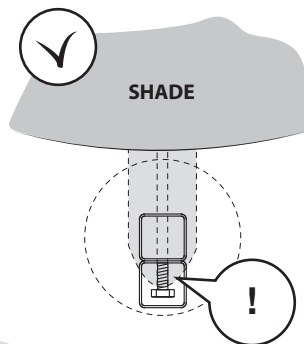
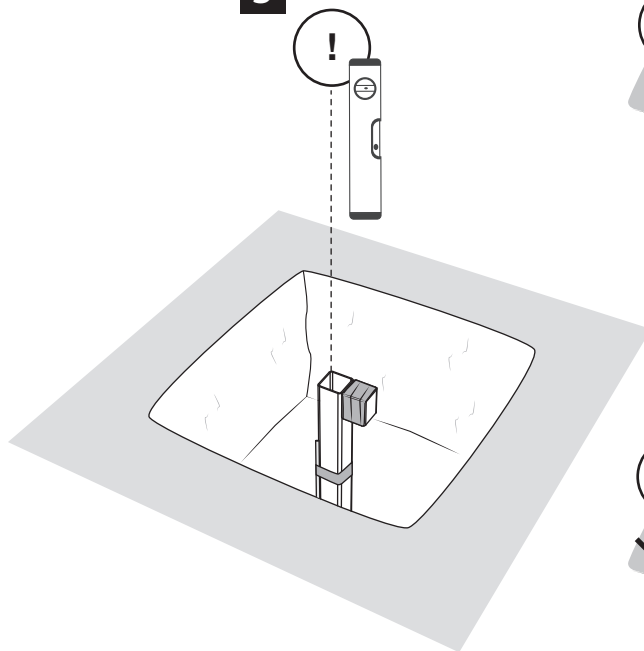

CONCRETE ANCHOR INSTALLATION



4

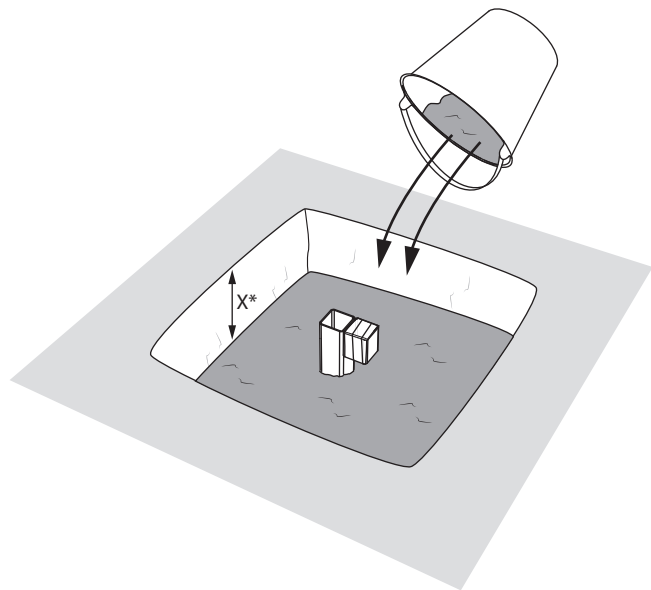

5

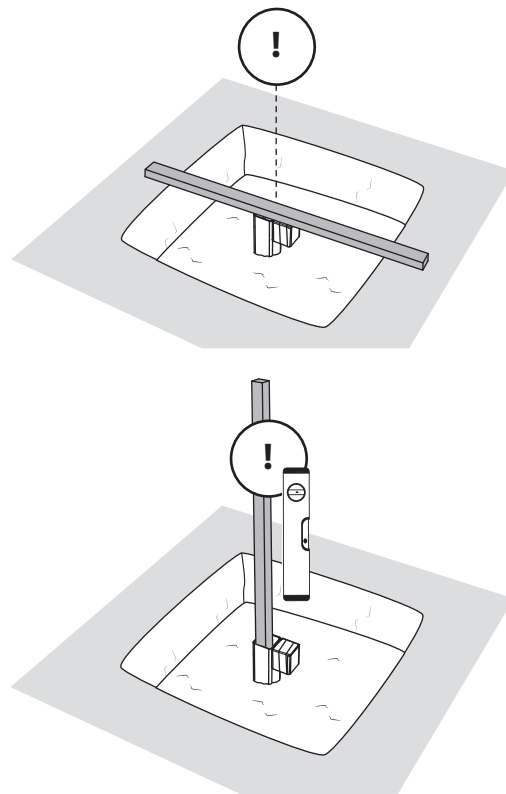

	 GRASS	 GRAVEL	 H TILES
 X*	10 cm	4 cm	= H

CONCRETE ANCHOR INSTALLATION



6

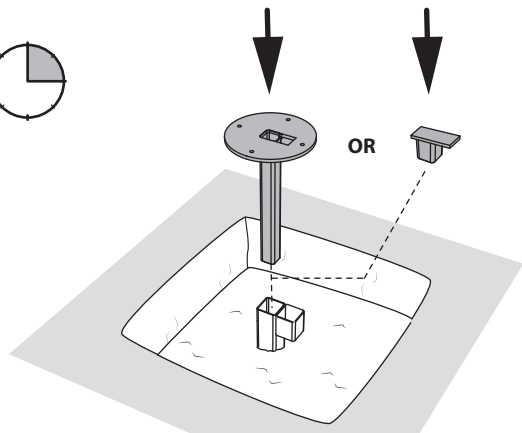

8

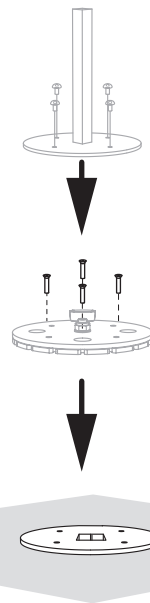

7

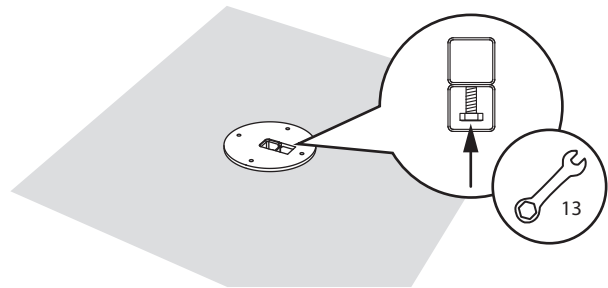

ECLIPSUM INSTALLATION

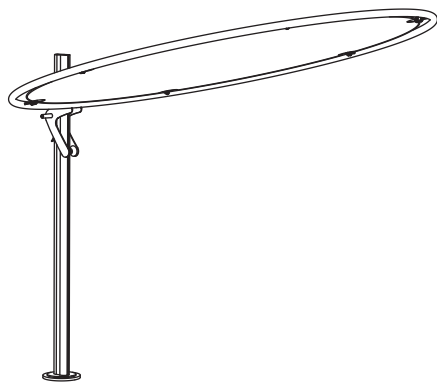

ECPRO0270CGREY00

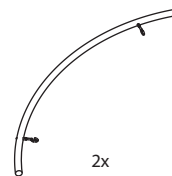

2x

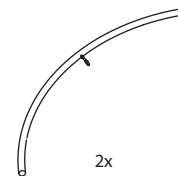

2x

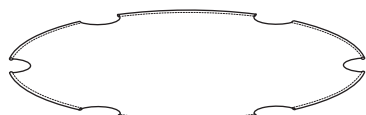

ECCOV***

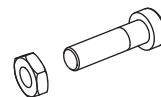
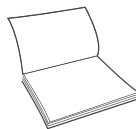

MANUTI0190 / MABOLI0800
4x

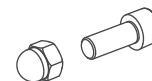

MANUTI0150 / MABOLI0591
3x

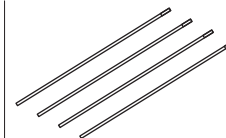

HECOME007W
4x

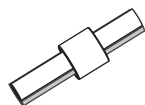

3x

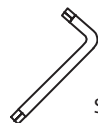

S4
MAKEY00040

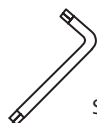

S5
MAKEY00050



S6
MAKEY00060



UMFIXSROT00000RO



ECFIXS215G8800RO

ECLIPSUM INSTALLATION

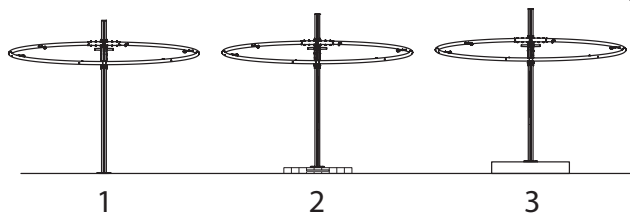
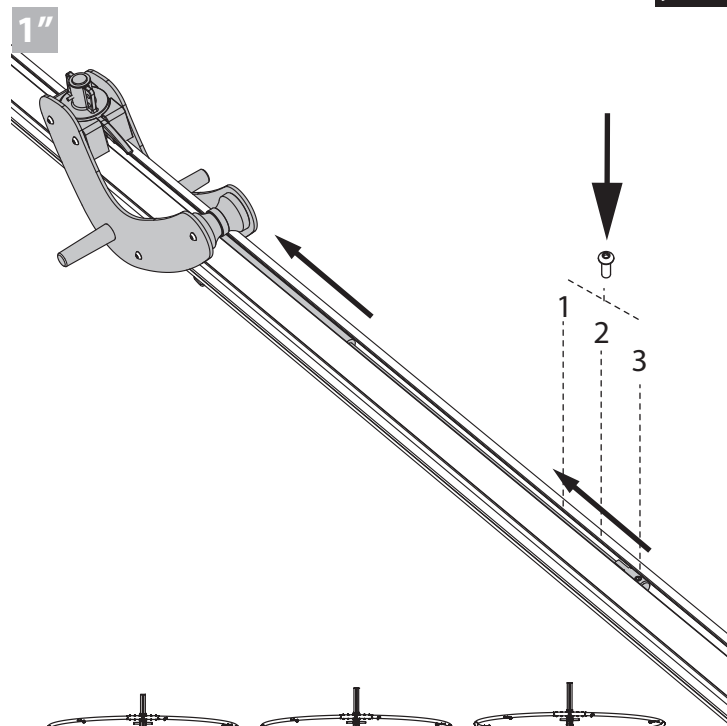
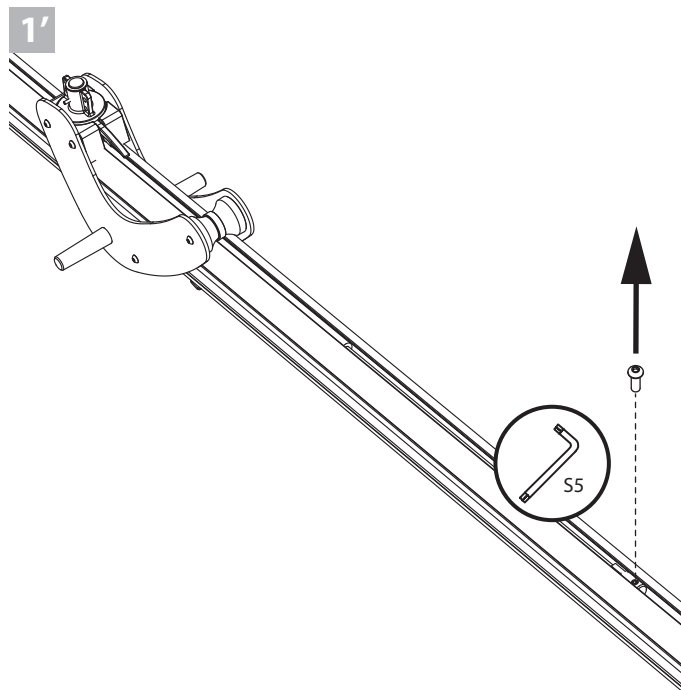

ECLIPSUM INSTALLATION



1

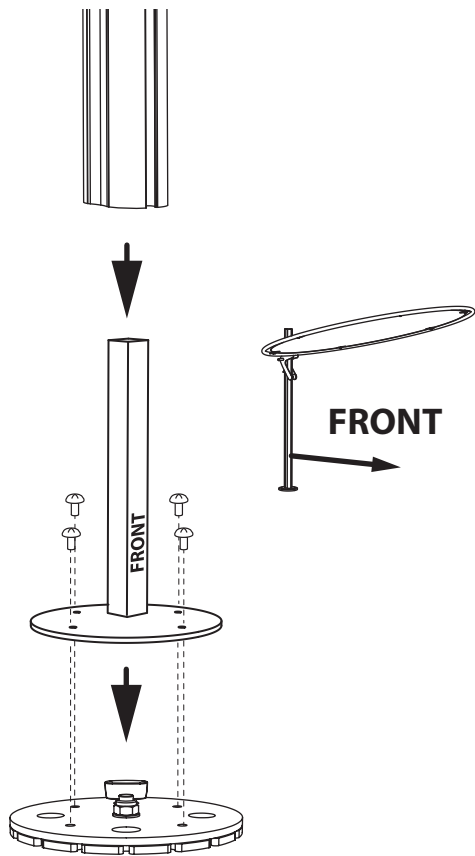

2

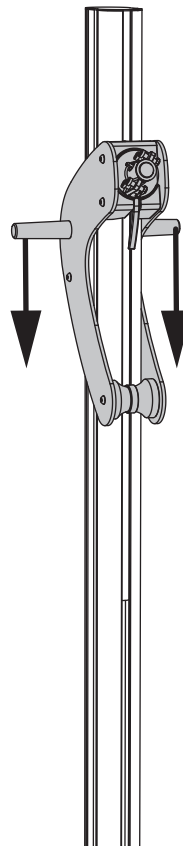

ECLIPSUM INSTALLATION



3

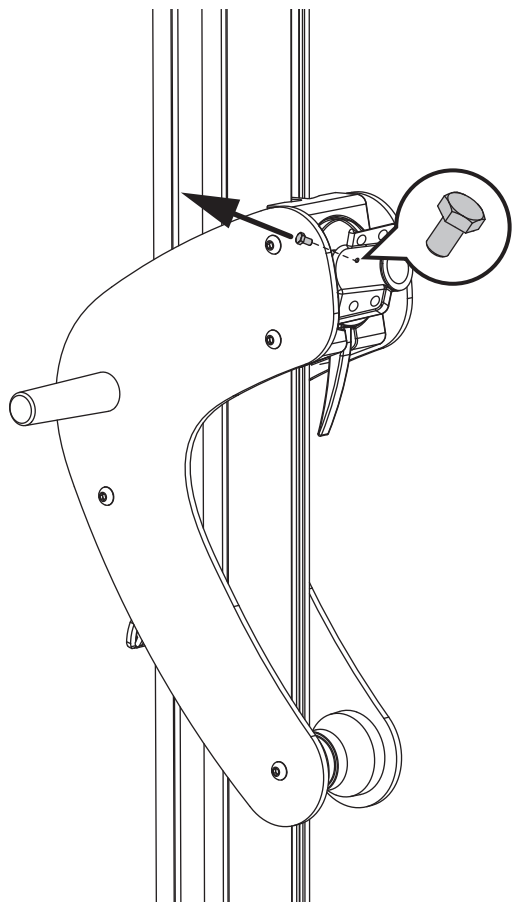

4

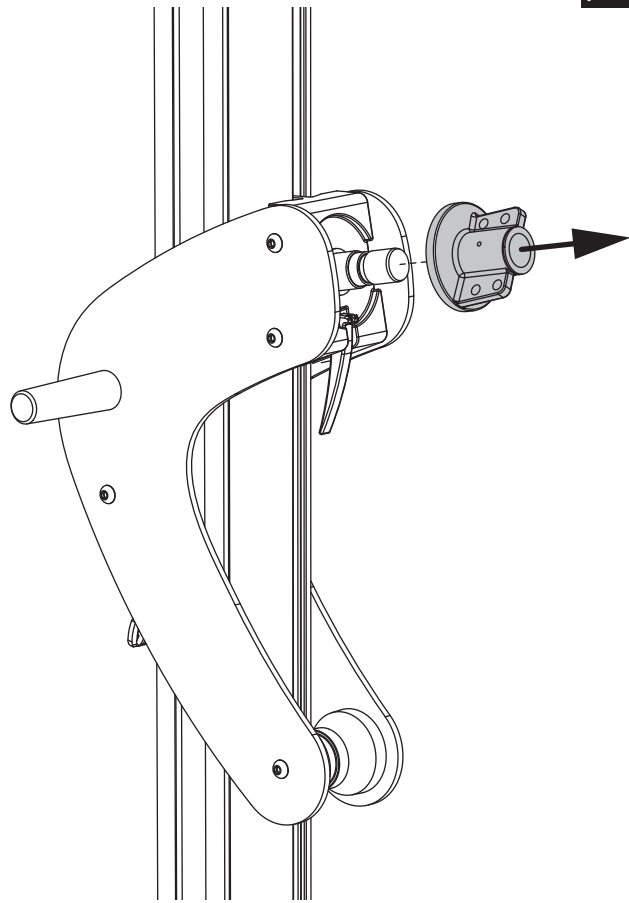

ECLIPSUM INSTALLATION



5

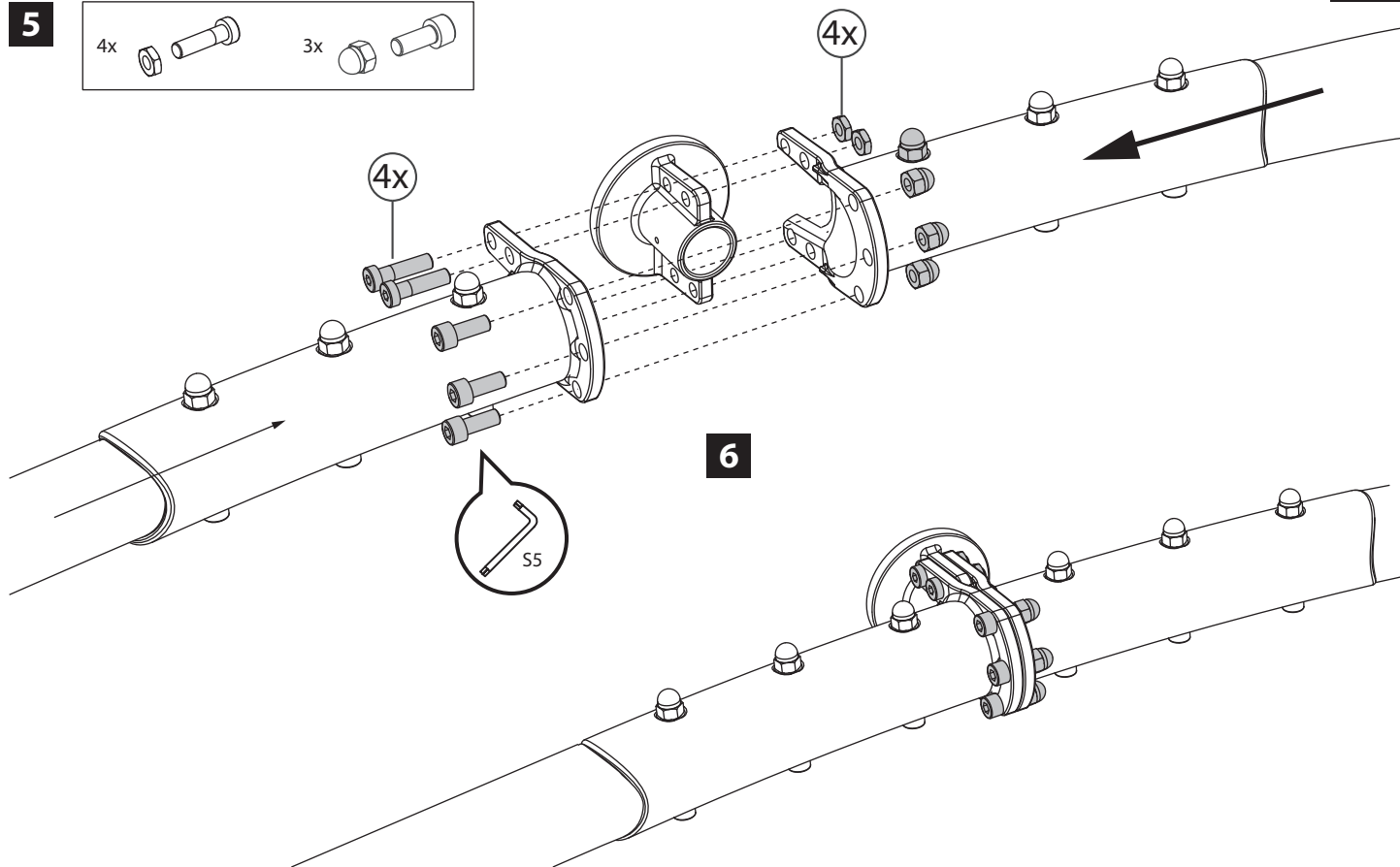
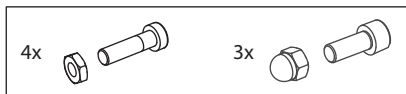

ECLIPSUM INSTALLATION

7

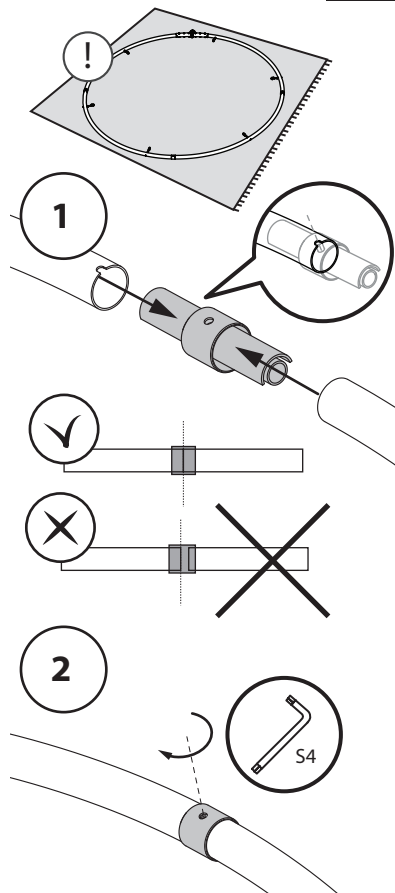
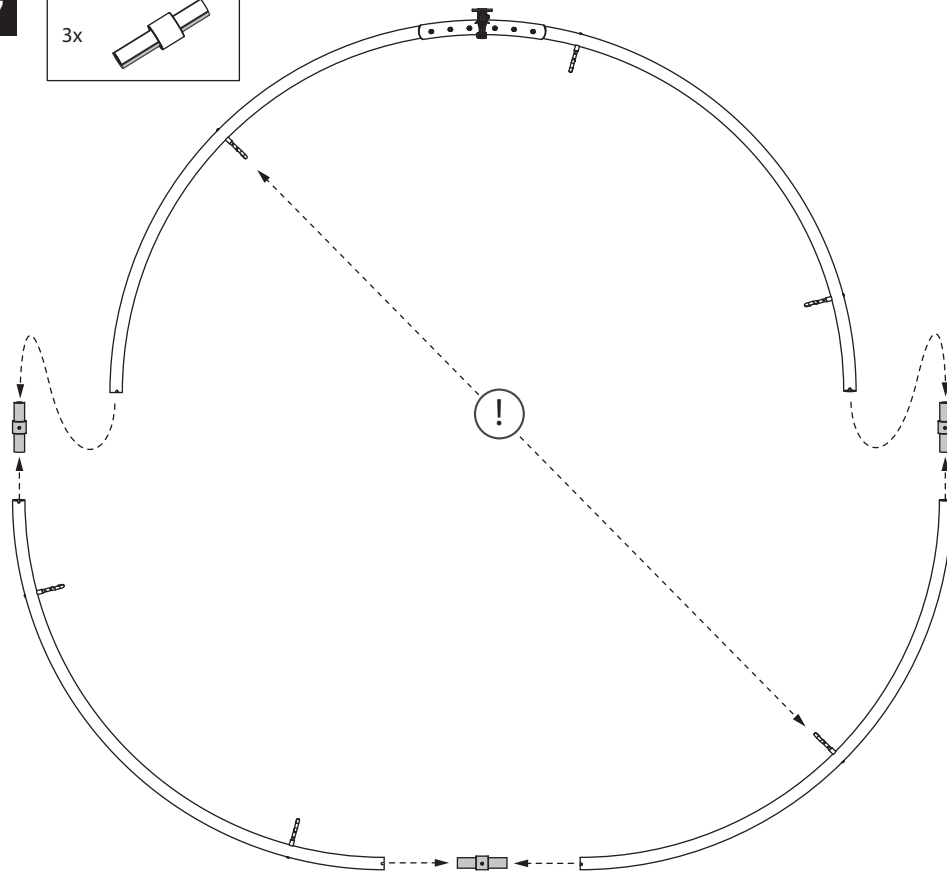
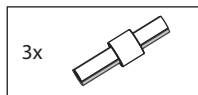

ECLIPSUM INSTALLATION

8

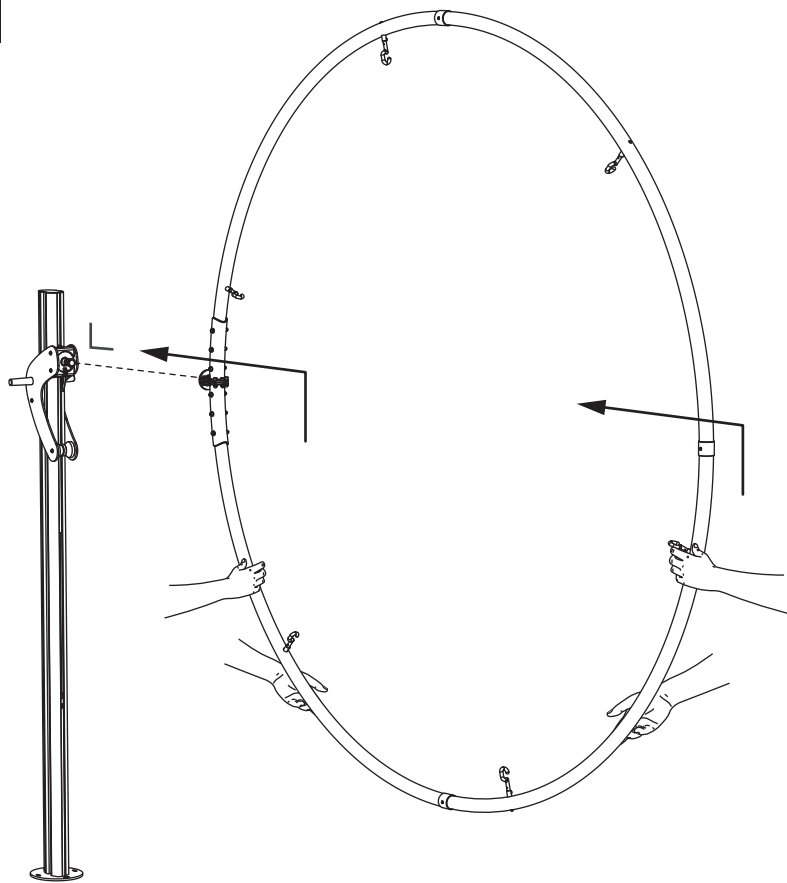

9

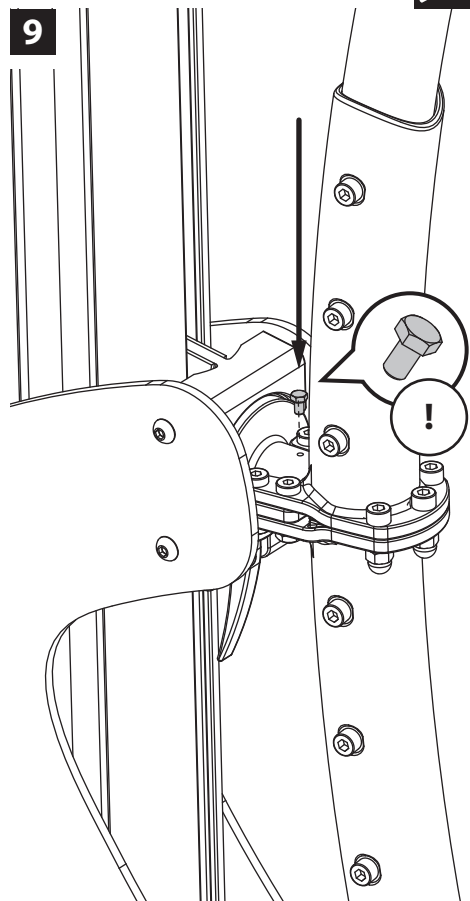

ECLIPSUM INSTALLATION

10

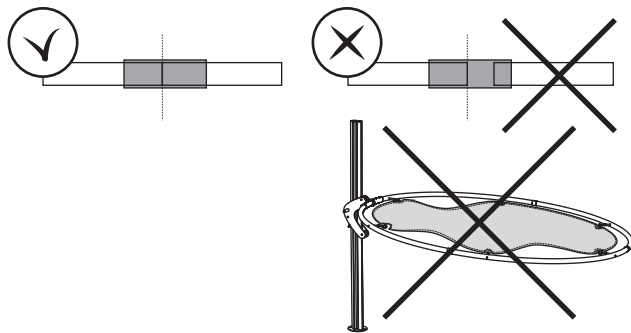
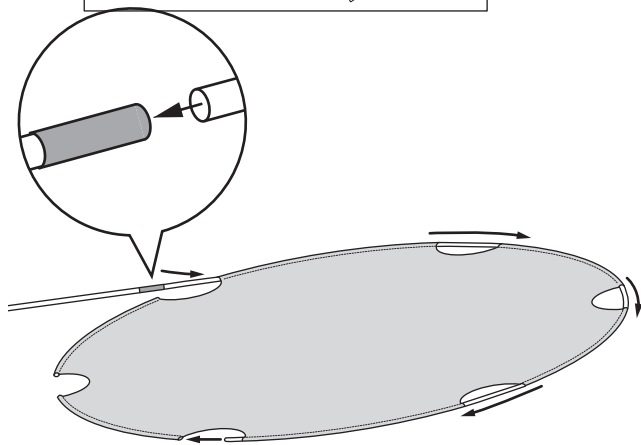
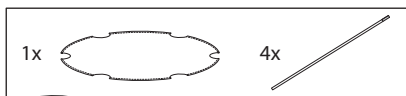

11

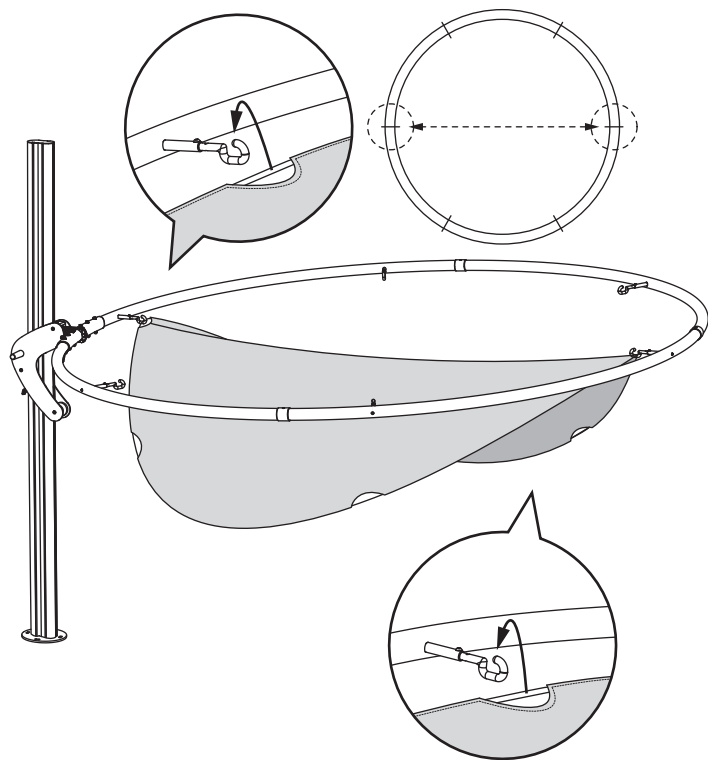



12

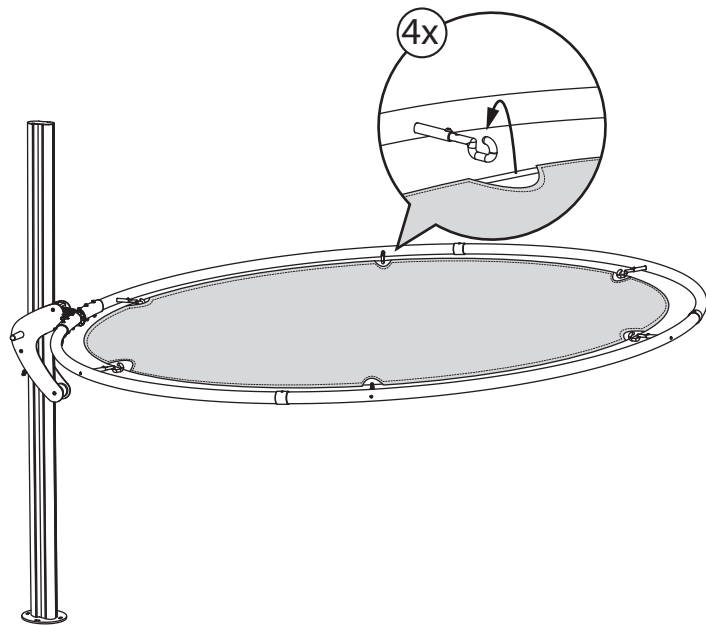

13

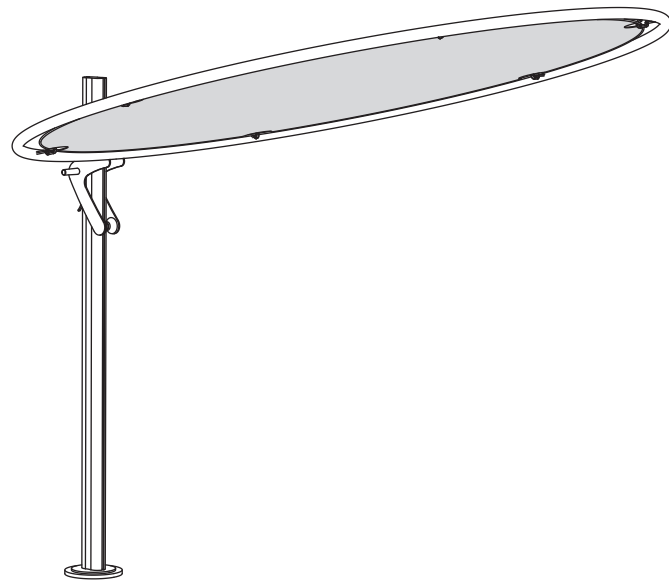

ECLIPSUM USER INSTRUCTIONS

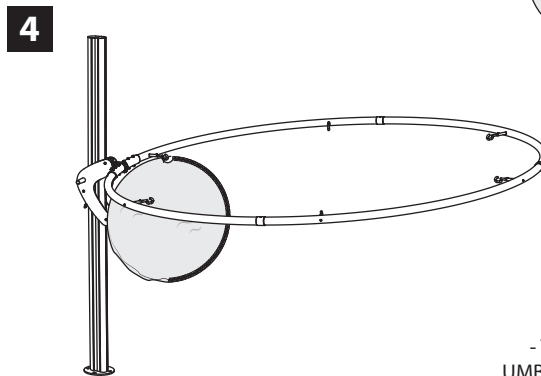
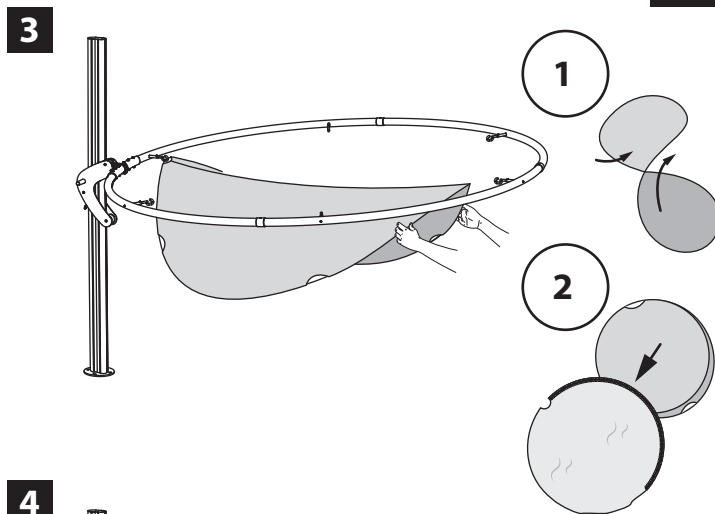
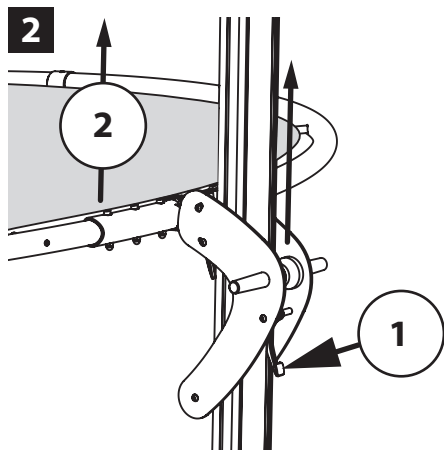
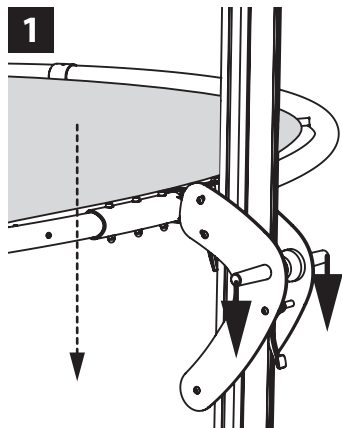

- YOUTUBE.COM/
UMBROSAINNOVATION
- UMBROSA.COM

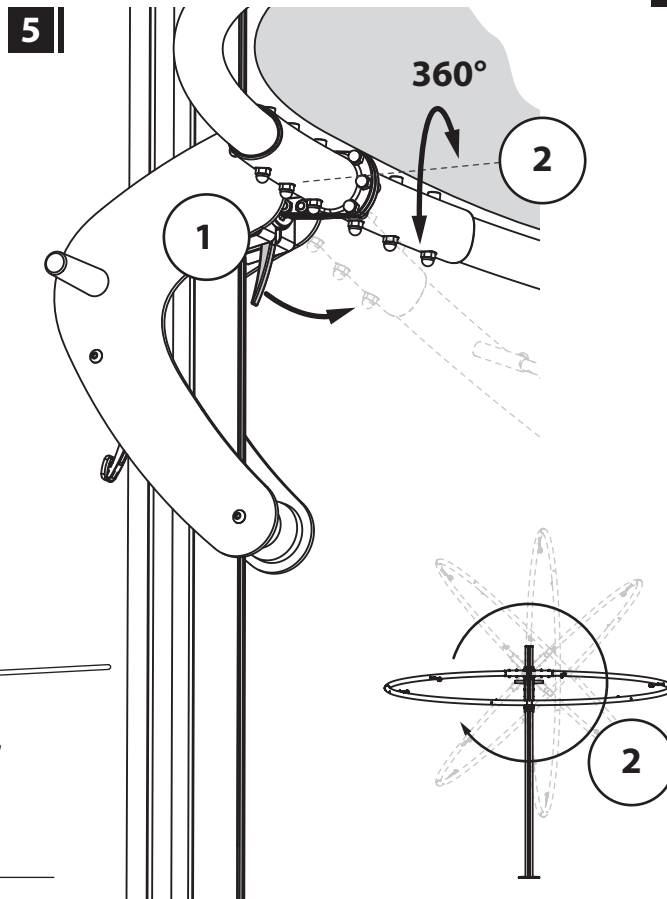
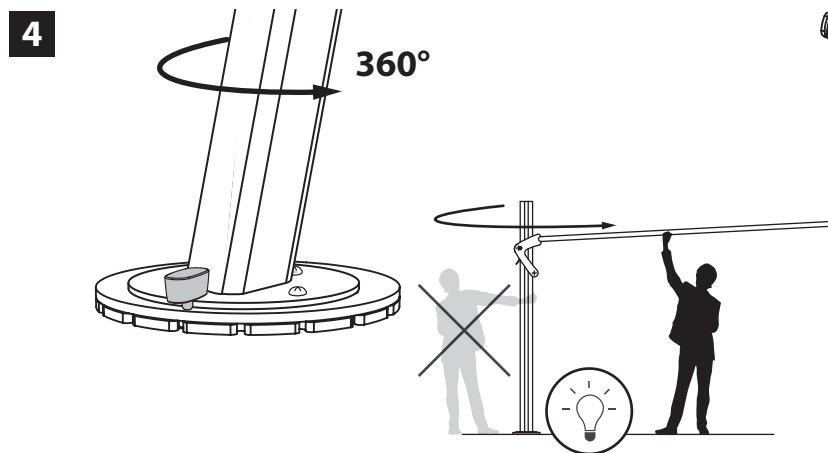
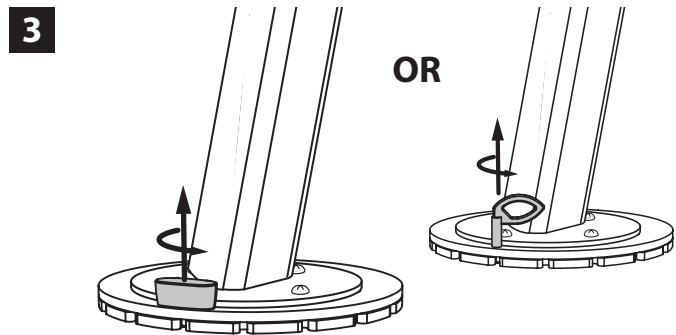

DO'S & DONT'S

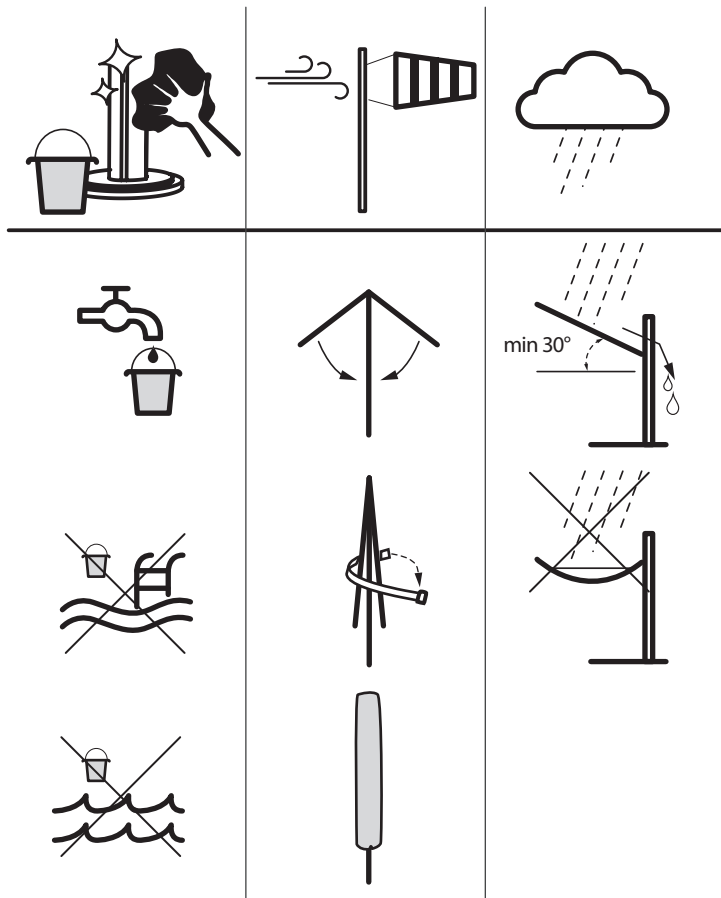

WWW.UMBROSA.COM

- ENG** Warranty conditions on website
- NL** Garantievoorwaarden op webpagina
- FR** Conditions de garantie sur le site Web
- DE** Garantiebedingungen auf der Webseite
- ES** Condiciones de garantía en el sitio web
- IT** Condizioni di garanzia sulla pagina web



- ENG** In order to prevent stainless steel from rusting, it is necessary to treat it frequently and preventatively. Umbrosa recommends cleaning and protecting the surface regularly. Cleaning can easily be done using standard dishwashing detergents. Afterwards, a protection layer can be applied onto the dry surface with a silicon spray. In an aggressive environment (maritime climate, chlorine, acid rain, aggressive industrial or urban environment) we recommend to clean the surface more frequently. Rust can be removed using a cloth and polishing paste. These kinds of products can be bought in do-it-yourself shops, but also in car specialty stores that sell several "stainless steel polishers".
- NL** Roestvast staal blijft enkel vrij van corrosie, wanneer deze goed en preventief wordt behandeld. Umbrosa raadt bijgevolg aan om regelmatig het oppervlak te reinigen en beschermen. Reinigen kan eenvoudig met warm water met afwasmiddel zoals "Dreft". Nadien brengt u op het droge oppervlakte een bescherm laag aan met bijvoorbeeld Silicone spray. In een agressieve omgeving (maritiem klimaat, chloor, zure regen, agressieve industriële of stedelijke omgeving), dient men de frequentie van dit preventief onderhoud op te drijven. Wanneer lichte roest zichtbaar is, dient deze te worden verwijderd met doek en speciale polierpasta. Dergelijke producten zijn te koop in Doe-het-Zelf zaken, alsook in autospecialzaken waar men verschillende "stainless steel polishers" verkoopt.
- FR** Pour éviter que L'acier inoxydable corrode, c'est nécessaire de traiter la surface régulièrement. Umbrosa conseille de nettoyer et protéger régulièrement la surface en utilisant l'eau chaude et un peu de détergent. Après, sur la surface sèche, vous pouvez appliquer une couche de protection avec, par exemple, un spray de Silicone. Surtout dans un environnement agressif (climat maritime, chlore, pluie acide, environnement industriel ou urbaine agressif) nous recommandons de nettoyer fréquemment la surface. Vous pouvez éliminer des éventuelles taches de rouille avec un chiffon et du cirage. Vous pouvez trouver ce type de produits dans des magasins bricolage, mais aussi dans des magasins spécialisés, ou on vend plusieurs "stainless steel polishers".
- DE** Edelstahl bleibt nur frei von Korrosion, wenn dieser gut und Präventiv behandelt wird. Umbrosa empfiehlt regelmäßig die Oberfläche zu reinigen und zu schützen. Reinigung kann problemlos mit warmem Wasser mit Seife. Danach bearbeiten Sie die trockene Oberfläche mit einer Schutzschicht z.B. Silikon spray. In einem aggressiven Umfeld (Seeklima, Chlor, saurer Regen, aggressive Industrie- oder städtischen Umwelt) sollte man diese Behandlung häufig machen. Sichtbaren Rost sollte mit Tuch und spezielle Polierwerkzeuge Paste entfernt werden. Solche Produkte findet man in Baumärkten sowie in Auto Läden wo man verschiedene "Edelstahl Polierer verkauft".
- ES** Acero inoxidable sólo permanece libre de corrosión, cuando esta bien y se trata como una medida preventiva. Umbrosa recomienda de limpiar regularmente la superficie para y proteger. Limpieza puede fácilmente con agua tibia con jabón del plato. Luego, lleva sobre la superficie seca con una capa protectora para por ejemplo spray de silicona. En ambientes agresivos (clima marítimo, cloro, lluvia ácida, agresivo ambiente urbano o industrial), la frecuencia de este mantenimiento preventivo para arriba. Cuando el moho visible, se debe retirar con paño y pasta de pulir especial. Estos productos se venden en ferreterías, así como en tiendas de coches donde uno diferentes vende "pulidores de acero inoxidable".
- IT** Per prevenire l'arrugginarsi dell'acciaio inox, è necessario curarlo frequentemente e preventivamente. Umbrosa consiglia di pulire e proteggere frequentemente la superficie. E' possibile pulire l'acciaio inox con aqua calda e detergente. Dopo aver pulito la superficie, la potete proteggere applicando sulla superficie asciutta uno strato protettivo con, per esempio, lo spray al silicone. In un ambiente aggressivo (clima marittimo, cloro, pioggia acida, ambiente aggressivo industriale o urbano) consigliamo di pulire la superficie più spesso. E' possibile rimuovere possibili macchie di ruggine con uno straccio e un po' di lucidante. Questi prodotti sono disponibili in negozi fai da te, ma anche in negozi specializzati (come quelli che vendono i prodotti per pulire le macchine) che vendono vari "stainless steel polishers".

SERIAL NUMBER

SERIENUMMER / NUMÉRO DE SÉRIE / ORDNUMGSNUMMER / NÚMERO DE SERIE / NUMERO DI SERIE

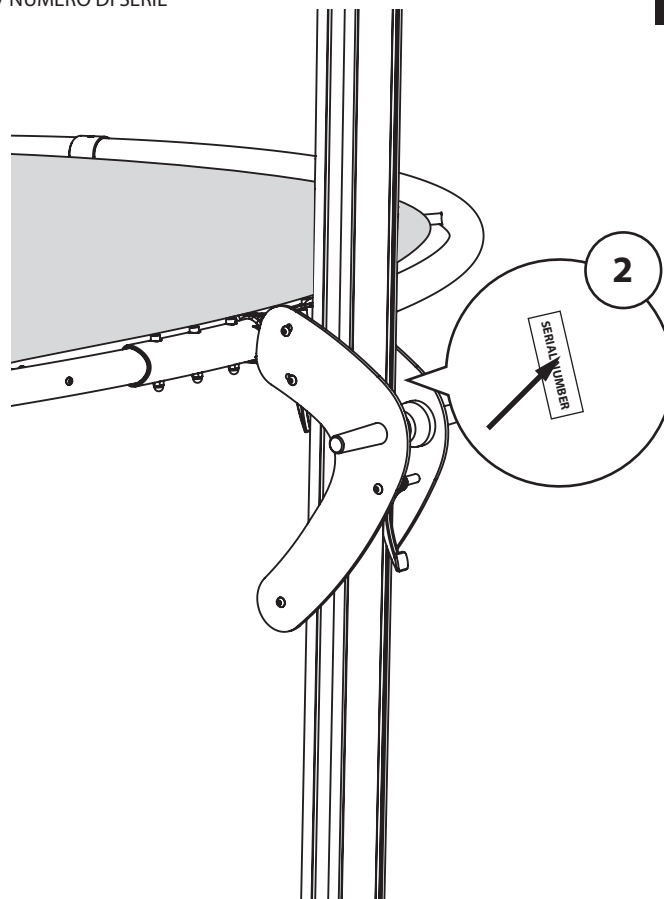
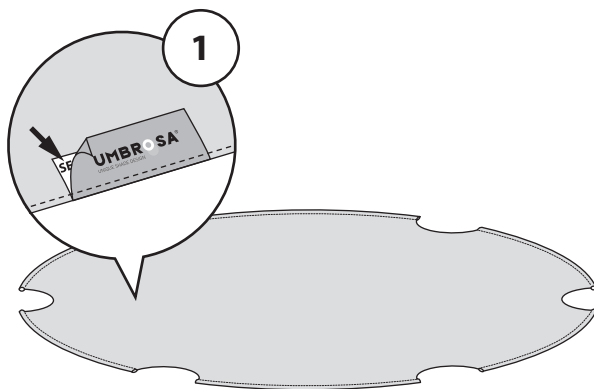

SPARE PARTS

ECLIPSUM

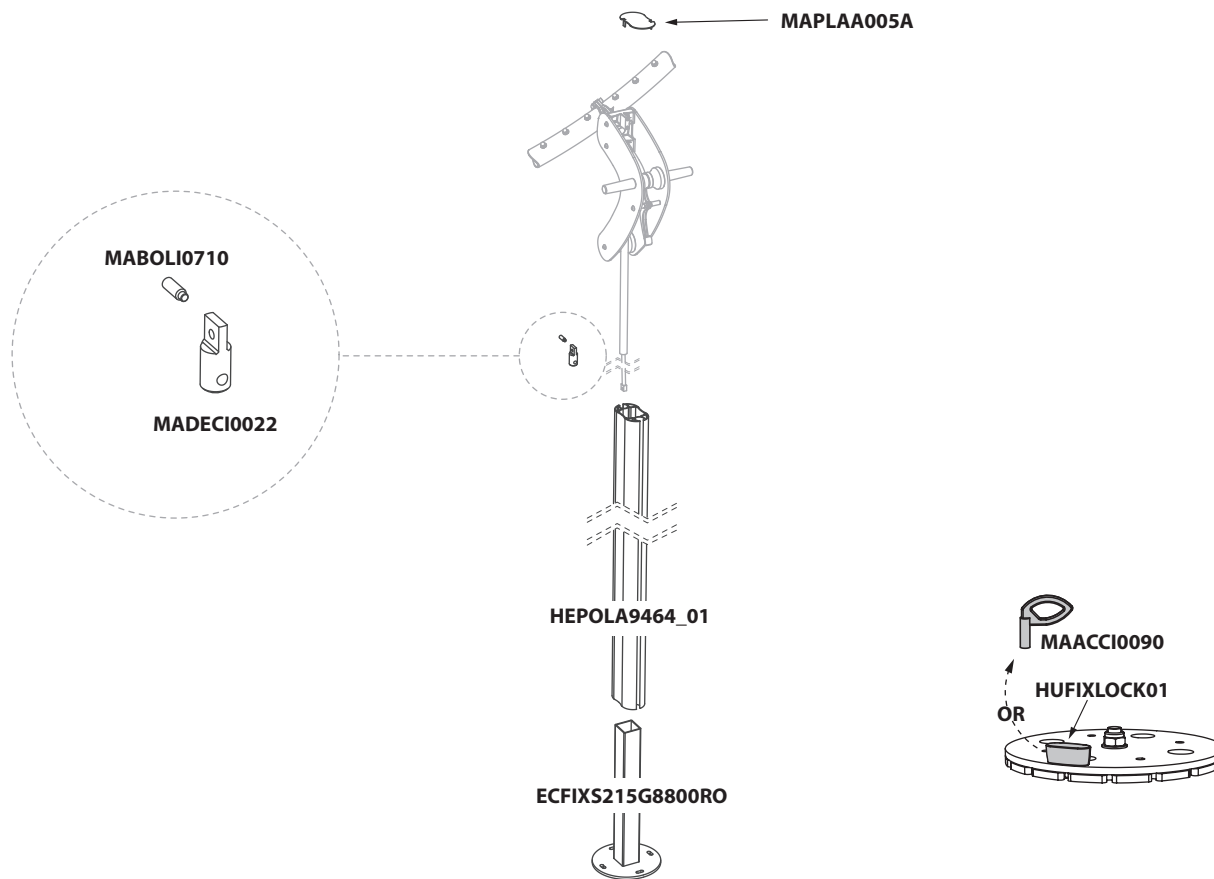

SPARE PARTS

ECLIPSUM

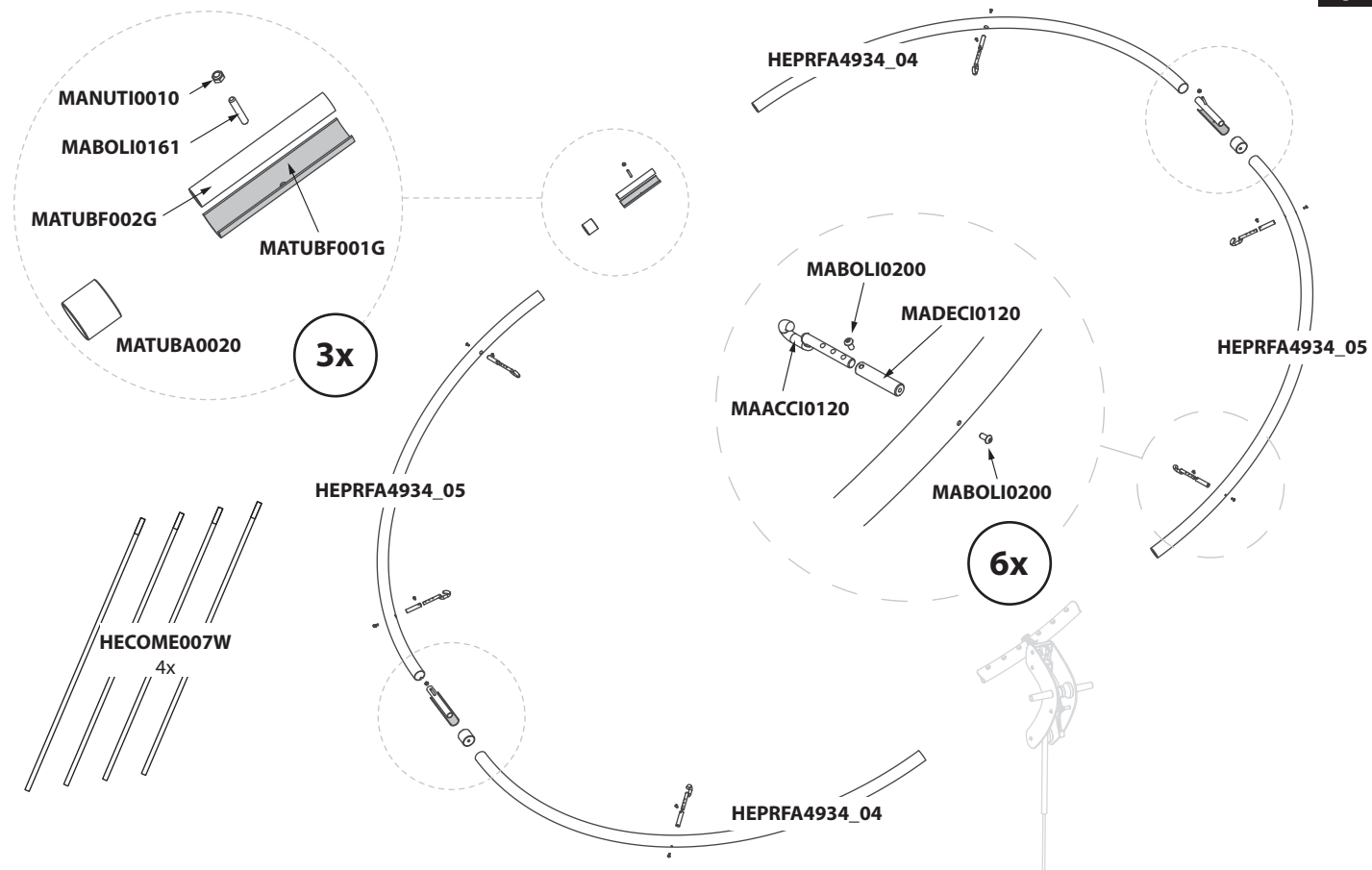

SPARE PARTS

ECLIPSUM

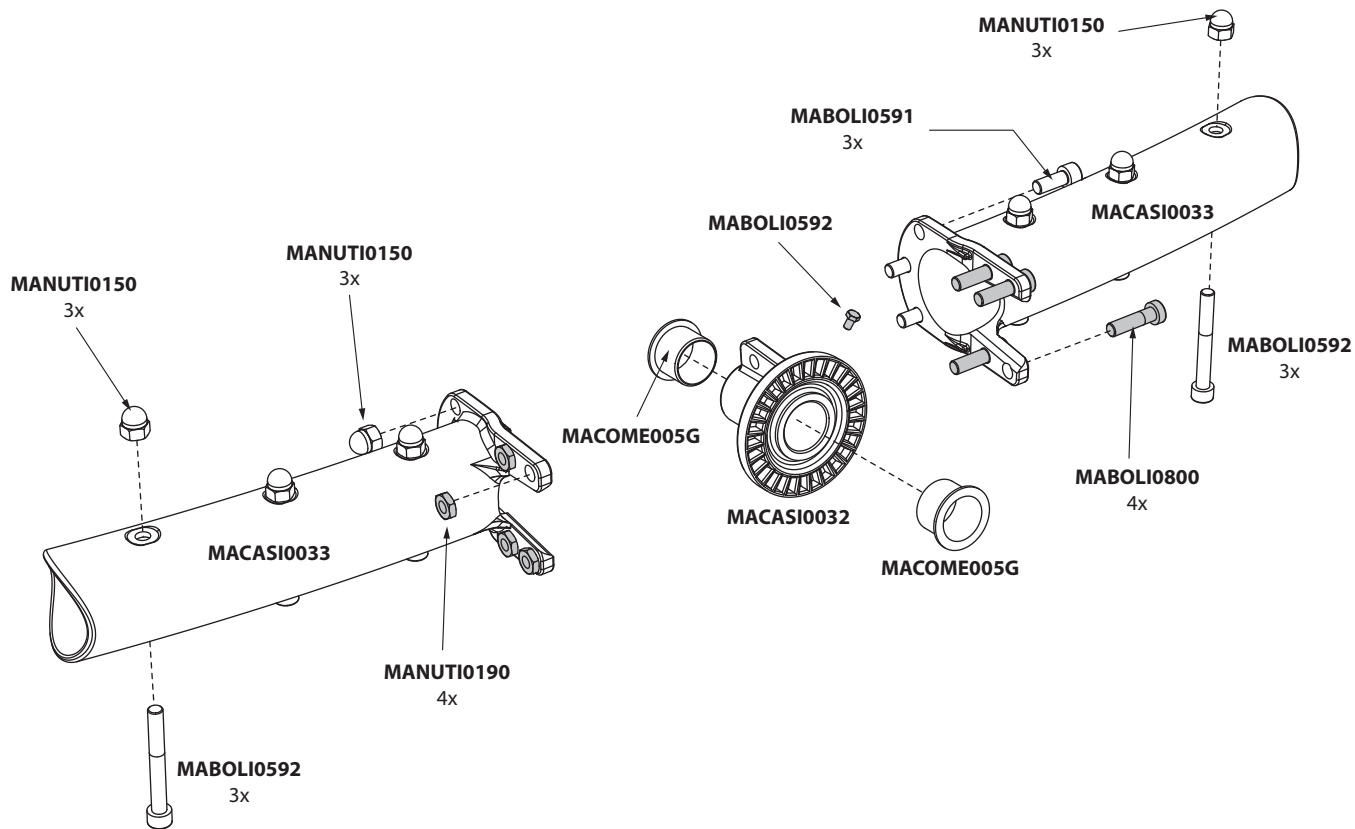

SPARE PARTS

ECLIPSUM

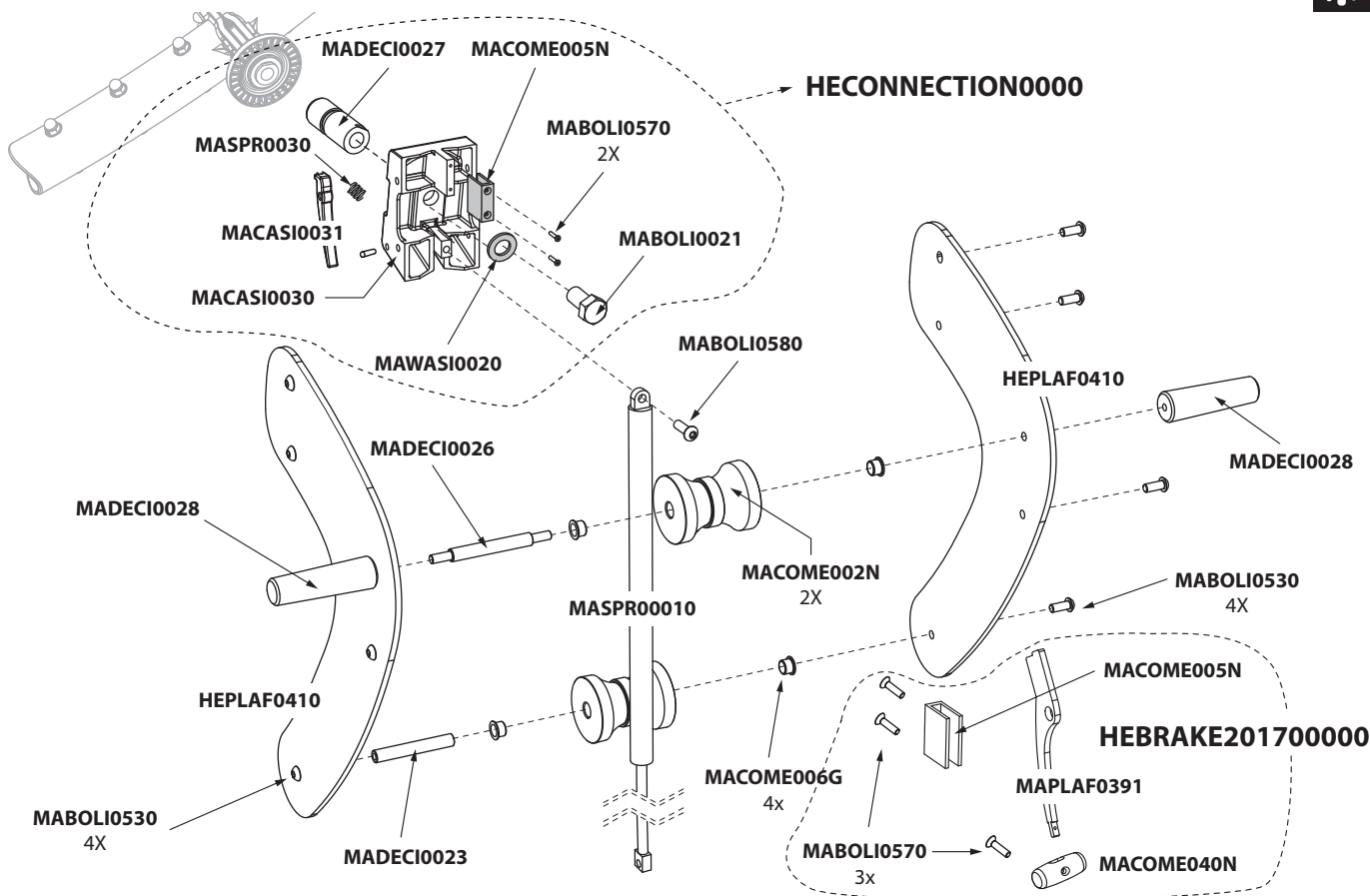

DISCOVER THE UMBROSA WORLD OF SHADE



[YOUTUBE.COM/UMBROSAINNOVATION](https://www.youtube.com/umbrosainnovation)

UMBROSA.COM

[FACEBOOK.COM/UMBROSA](https://www.facebook.com/umbrosa)



Heirweg 198A, 8800 Roeseleare, Belgium.
T: +32 51 30.22.60 | F: +32 51 30.22.62 | E: info@umbrosa.com | www.umbrosa.com

Version 010222

The content of this document, in particular the mentioned models, is protected by copyrights and/or design rights. The present document and its content is communicated to you for information purposes only. Any partial or total reproduction or any other use without our prior written permission is strictly prohibited. This technical sheet remains subject to possible changes. Of course we do our best to eliminate all mistakes, but Umbrosa is not responsible for the errors in the documentation of products. All measurements are approximate and are provided for informational purposes only.